



## Project Profile: Trans Pennine Express

<b>Customer:</b>	Siemens AG
<b>Project Type:</b>	New Build
<b>Operator:</b>	First Group
<b>Franchisee:</b>	Trans Pennine Express
<b>Train Owner:</b>	Angel
<b>Train Mfg:</b>	Siemens AG
<b>Train Class:</b>	185 Desiro
<b>Number of Trains:</b>	51
<b>Number of Cars:</b>	3



## System Overview

The CCTV digital recorder module TransitCam TC-100 provides surveillance recording from up to 8 camera inputs. This recording function operates automatically and continuously without any intervention from the driver. At all times digital image frames for each camera are recorded on the digital video recorder's removable Hard Disk Drive.

There is one TransitCam TC-100 unit installed in each 3-car unit. It is housed in a single compact enclosure equivalent to a 4U form factor.



511 Davis Drive, Ste. 300  
Morrisville, NC 27560  
919.472.5000 [www.integrían.com](http://www.integrían.com)



## Project Features

- High quality, full color, digital hardware MPEG-4 image compression
- Capture rate of 12.5 frames per second per camera (PAL)
- Resolution of 2CIF
- 126 hours of data storage
- Isolated RS-232 diagnostics and service port
- Storage media operates in overwrite mode with older files being overwritten by current video records
- Local LCD text status display for diagnostics and service
- Configurable car number for incorporation in data files and evidence audit
- 8 Video inputs available, 8 camera configuration
- Time and date received from PIS system over LON network. No time drift, user maintenance or setting requirements for on-train clock calendars
- Internal battery-backed clock calendar maintains time and date while power is off and where PIS signal is not available. Clock calendar is automatically synchronized when PIS signal is next available
- Integrated, 480 line color camera units, electrically isolated, incorporate housing, connector, lens and mounting spacer
- Single coax cable to each camera carries both signal and power
- Local video output can be switched to any camera for camera testing and diagnostics
- Full width 19 inch, 4U rack mount recorder unit



TransitCam TC-100



511 Davis Drive, Ste. 300  
Morrisville, NC 27560  
919.472.5000 [www.integrían.com](http://www.integrían.com)



## System Architecture

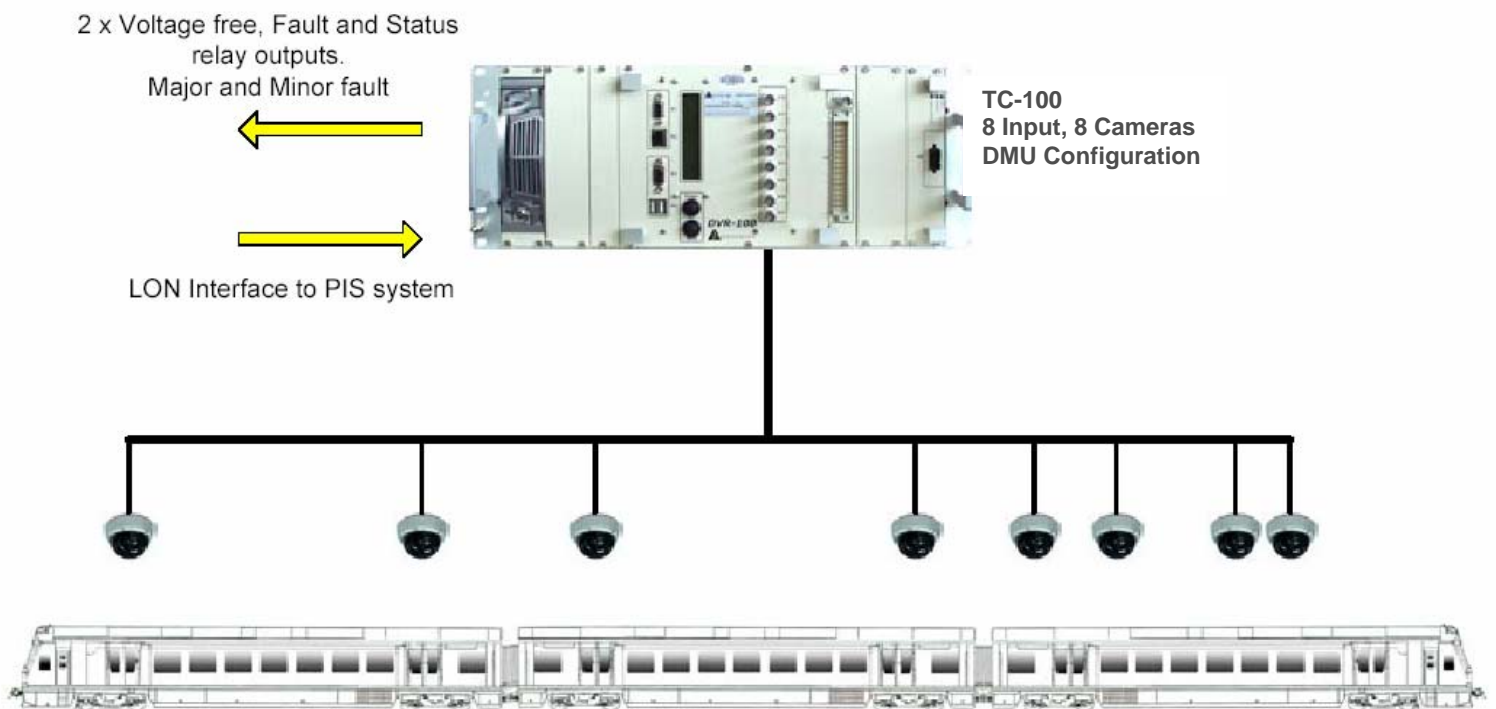

511 Davis Drive, Ste. 300  
Morrisville, NC 27560  
919.472.5000 [www.integrrian.com](http://www.integrrian.com)